

Features

- 400Gb/s to 4x100Gb/s data rate
- 8x 50Gb/s PAM4 modulation
- Case temperature range of 0°C to +70°C
- +3.3V single power supply
- 8x50G PAM4 retimed 400GAUI-8 electrical interface aligned with IEEE 802.3bs
- Compliant to CMIS V4.0
- RoHS compliant

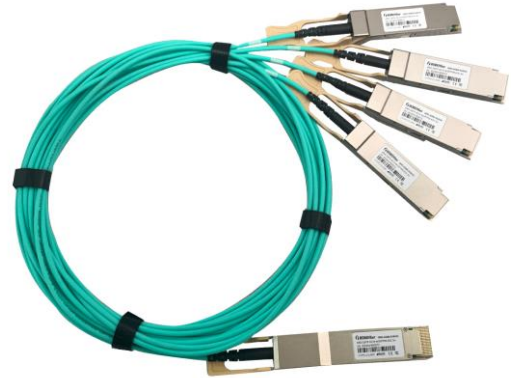

Applications

- 400GAUI-8
- Other 400G optical links

Order Information

Table 1-Order Information

Part No.	Bit Rate (Gbps)	Modulation	Distance	Fiber Type	DDMI	Connector	Temp ^{note1}
QDD-4Q56-xxAOC	8x50	PAM4	0.5~50m	MMF	YES	N/A	0°C~+70°C

Note:1 Case Temperature

Absolute Maximum Ratings

Table2- Absolute Maximum Ratings

Parameter	Symbol	Min.	Typical	Max.	Unit	Notes
Supply Voltage	VCC ₃	-0.5	-	+3.6	V	
Storage Temperature	T _s	-10	-	+70	°C	
Operating Humidity	RH	+5	-	+85	%	1

Note:1 No condensation

Recommended Operating Conditions

Table 3- Recommended operating Conditions

Parameter	Symbol	Min.	Typical	Max.	Unit	Notes
Operating Case Temperature	T _c	0	-	+70	°C	
Power Supply Voltage	V _{cc}	3.135	3.3	3.465	V	
Power Dissipation per QSFPDD	P _d	-	-	10	W	1
Power Dissipation per QSFP56	P _d	-	-	2.5	W	1
Bit Rate	BR	-	26.5625	-	GBaud	2

Note:

- 1 Per terminal
- 2 Per channel, PAM4

Characteristics

Table 4- Electrical Characteristics

Parameter	Symbol	Unit	Min	Typ	Max	Notes
Transmitter						
Signaling rate (each lane)	SR	GBaud	26.5625 ± 100 ppm			
Differential data input voltage per lane	V _{in,pp,diff}	mV	-	-	900	
Differential termination mismatch	-	%	-	-	10	
Single-ended voltage tolerance range	-	V	-0.4	-	3.3	
DC common mode voltage	-	mV	-350	-	2850	
Receiver						
Signaling rate (each lane)	SR	GBaud	26.5625 ± 100 ppm			
Differential output voltage	-	mV	-	-	900	
Near-end ESMW (Eye symmetry mask width)	-	UI	0.265	-	-	
Near-end Eye height, differential (min)	-	mV	70	-	-	
Far-end ESMW (Eye symmetry mask width)	-	UI	0.2	-	-	
Far-end Eye height, differential (min)	-	mV	30	-	-	
Differential termination mismatch	-	%	-	-	10	
Transition time (min, 20% to 80%)	-	ps	9.5	-	-	
DC common mode voltage	-	mV	-350	-	2850	
Bit Error Ratio	-	-	-	-	2.4E-4	1

Note:

- 1 Pattern PRBS31Q

Recommended Interface

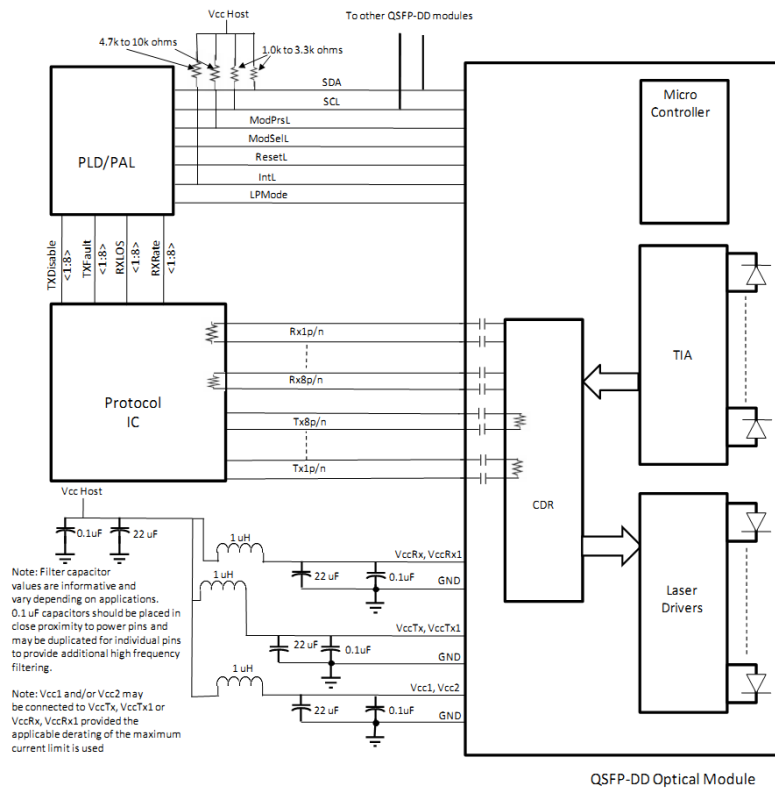

Figure 1, Recommended Interface Circuit

Pin arrangement

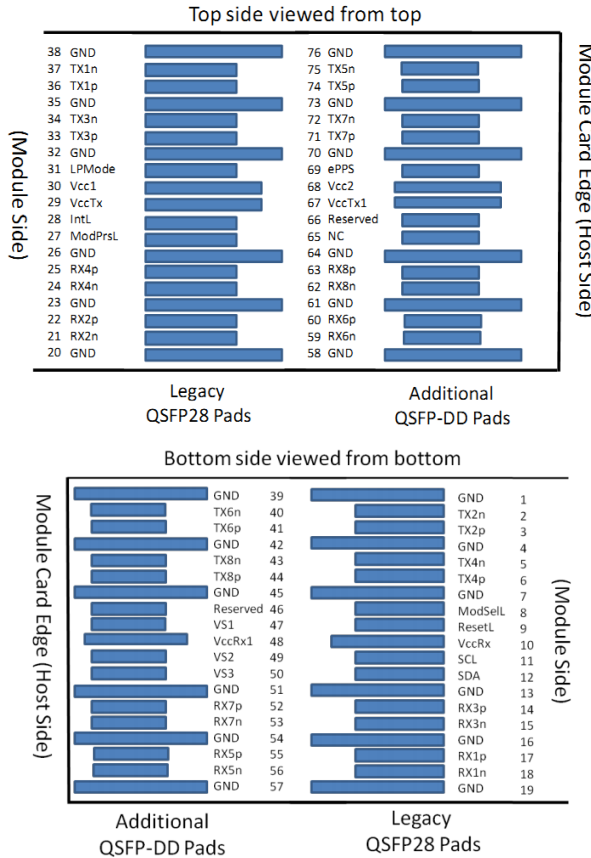

Figure 2, Pin View for QSF-DD

Table 5-Pin Function Definitions for QSFP-DD

Pad	Logic	Symbol	Description	Plug Sequence ¹	Notes
1		GND	Ground	1B	1
2	CML-I	Tx2n	Transmitter Inverted Data Input	3B	
3	CML-I	Tx2p	Transmitter Non-Inverted Data Input	3B	
4		GND	Ground	1B	1
5	CML-I	Tx4n	Transmitter Inverted Data Input	3B	
6	CML-I	Tx4p	Transmitter Non-Inverted Data Input	3B	
7		GND	Ground	1B	1
8	LVTTL-I	ModSelL	Module Select	3B	
9	LVTTL-I	ResetL	Module Reset	3B	
10		VccRx	+3.3V Power Supply Receiver	2B	2
11	LVCNOS-I/O	SCL	2-wire serial interface clock	3B	
12	LVCNOS-I/O	SDA	2-wire serial interface data	3B	
13		GND	Ground	1B	1
14	CML-O	Rx3p	Receiver Non-Inverted Data Output	3B	
15	CML-O	Rx3n	Receiver Inverted Data Output	3B	
16		GND	Ground	1B	1
17	CML-O	Rx1p	Receiver Non-Inverted Data Output	3B	
18	CML-O	Rx1n	Receiver Inverted Data Output	3B	
19		GND	Ground	1B	1
20		GND	Ground	1B	1
21	CML-O	Rx2n	Receiver Inverted Data Output	3B	
22	CML-O	Rx2p	Receiver Non-Inverted Data Output	3B	
23		GND	Ground	1B	1
24	CML-O	Rx4n	Receiver Inverted Data Output	3B	
25	CML-O	Rx4p	Receiver Non-Inverted Data Output	3B	
26		GND	Ground	1B	1
27	LVTTL-O	ModPrsL	Module Present	3B	
28	LVTTL-O	IntL	Interrupt	3B	
29		VccTx	+3.3V Power supply transmitter	2B	2
30		Vcc1	+3.3V Power supply	2B	2
31	LVTTL-I	LPMODE	Low Power mode;	3B	
32		GND	Ground	1B	1
33	CML-I	Tx3p	Transmitter Non-Inverted Data Input	3B	
34	CML-I	Tx3n	Transmitter Inverted Data Input	3B	
35		GND	Ground	1B	1
36	CML-I	Tx1p	Transmitter Non-Inverted Data Input	3B	
37	CML-I	Tx1n	Transmitter Inverted Data Input	3B	
38		GND	Ground	1B	1
39		GND	Ground	1A	1
40	CML-I	Tx6n	Transmitter Inverted Data Input	3A	
41	CML-I	Tx6p	Transmitter Non-Inverted Data Input	3A	
42		GND	Ground	1A	1
43	CML-I	Tx8n	Transmitter Inverted Data Input	3A	
44	CML-I	Tx8p	Transmitter Non-Inverted Data Input	3A	
45		GND	Ground	1A	1
46		Reserved	For future use	3A	3
47		VS1	Module Vendor Specific 1	3A	3
48		VccRx1	3.3V Power Supply	2A	2
49		VS2	Module Vendor Specific 2	3A	3
50		VS3	Module Vendor Specific 3	3A	3
51		GND	Ground	1A	1
52	CML-O	Rx7p	Receiver Non-Inverted Data Output	3A	
53	CML-O	Rx7n	Receiver Inverted Data Output	3A	
54		GND	Ground	1A	1
55	CML-O	Rx5p	Receiver Non-Inverted Data Output	3A	
56	CML-O	Rx5n	Receiver Inverted Data Output	3A	
57		GND	Ground	1A	1
58		GND	Ground	1A	1
59	CML-O	Rx6n	Receiver Inverted Data Output	3A	
60	CML-O	Rx6p	Receiver Non-Inverted Data Output	3A	
61		GND	Ground	1A	1
62	CML-O	Rx8n	Receiver Inverted Data Output	3A	
63	CML-O	Rx8p	Receiver Non-Inverted Data Output	3A	
64		GND	Ground	1A	1
65		NC	No Connect	3A	3
66		Reserved	For future use	3A	3
67		VccTx1	3.3V Power Supply	2A	2
68		Vcc2	3.3V Power Supply	2A	2
69	LVTTL-I	ePPS	Precision Time Protocol (PTP) reference clock input	3A	3
70		GND	Ground	1A	1
71	CML-I	Tx7p	Transmitter Non-Inverted Data Input	3A	
72	CML-I	Tx7n	Transmitter Inverted Data Input	3A	
73		GND	Ground	1A	1
74	CML-I	Tx5p	Transmitter Non-Inverted Data Input	3A	
75	CML-I	Tx5n	Transmitter Inverted Data Input	3A	
76		GND	Ground	1A	1

Note: 1. Circuit ground is internally isolated from chassis ground.

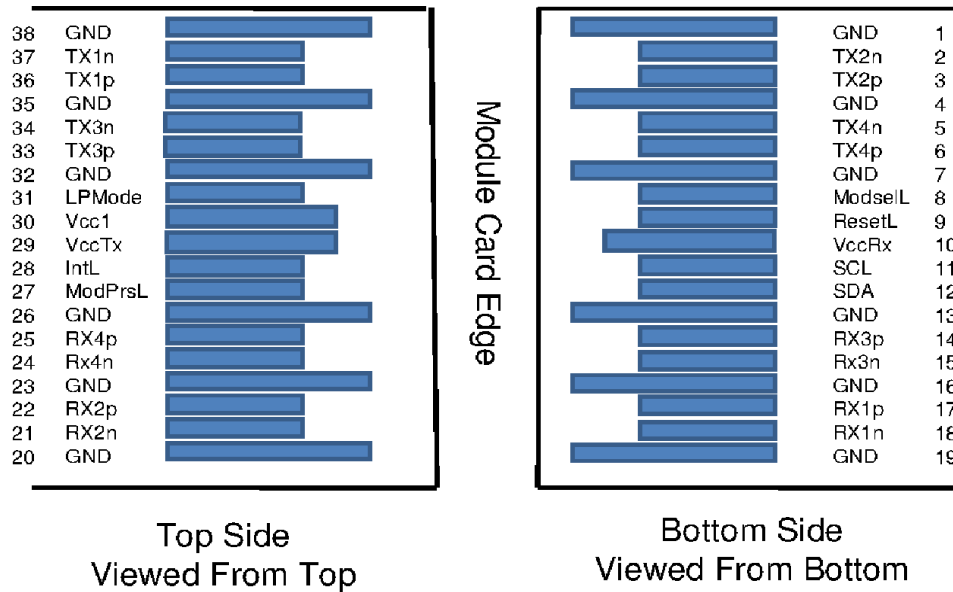

Figure 3, Pin View for QSFP56

Table 6-Pin Function Definitions for QSFP56

Pin	Symbol	Name/Description	Notes
1	GND	Ground	1
2	Tx2n	Transmitter Inverted Data Input	
3	Tx2p	Transmitter Non-Inverted Data Input	
4	GND	Ground	1
5	Tx4n	Transmitter Inverted Data Input	
6	Tx4p	Transmitter Non-Inverted Data Input	
7	GND	Ground	1
8	ModSelL	Module Select	
9	ResetL	Module Reset	
10	Vcc Rx	+3.3V Power Supply Receiver	
11	SCL	2-wire serial interface clock	
12	SDA	2-wire serial interface data	
13	GND	Ground	1
14	Rx3p	Receiver Non-Inverted Data Output	
15	Rx3n	Receiver Inverted Data Output	
16	GND	Ground	1
17	Rx1p	Receiver Non-Inverted Data Output	
18	Rx1n	Receiver Inverted Data Output	
19	GND	Ground	1
20	GND	Ground	1
21	Rx2n	Receiver Inverted Data Output	
22	Rx2p	Receiver Non-Inverted Data Output	
23	GND	Ground	1
24	Rx4n	Receiver Inverted Data Output	
25	Rx4p	Receiver Non-Inverted Data Output	

26	GND	Ground	1
27	ModPrsL	Module Present	
28	IntL	Interrupt	
29	Vcc Tx	+3.3V Power supply transmitter	
30	Vcc1	+3.3V Power supply	
31	LPMMode	Low Power Mode	
32	GND	Ground	1
33	Tx3p	Transmitter Non-Inverted Data Input	
34	Tx3n	Transmitter Inverted Data Input	
35	GND	Ground	1
36	Tx1p	Transmitter Non-Inverted Data Input	
37	Tx1n	Transmitter Inverted Data Input	
38	GND	Ground	1

Memory Map

Compatible with QSFP-DD CMIS rev 4.0.

Mechanical

Unit mm

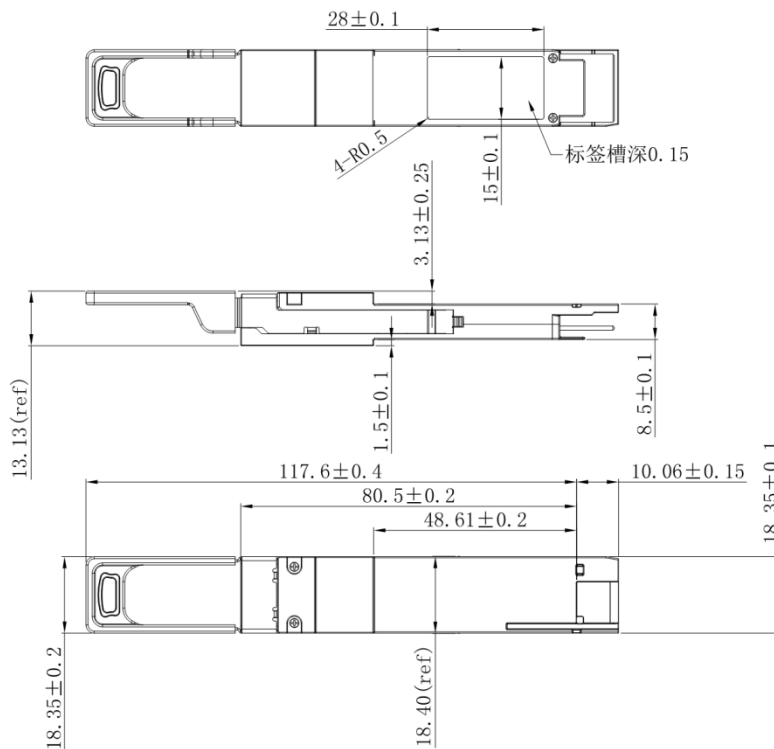
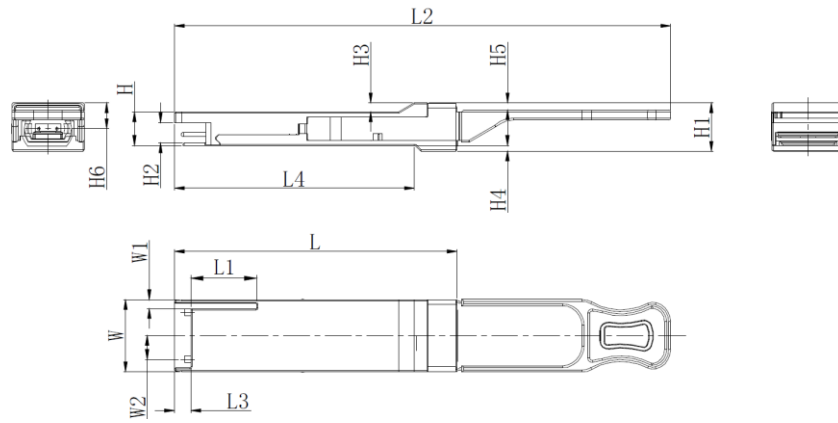

Figure 4, Mechanical Diagram for QSFP-DD



	L	L1	L2	L3	L4	W	W1	W2	H	H1	H2	H3	H4	H5	H6
Max	72.2	-	128	4.35	61.4	18.45	-	6.2	8.6	12.4	5.35	2.5	1.6	2.0	-
Type	72.0	-	-	4.20	61.2	18.35	-	-	8.5	12.2	5.2	2.3	1.5	1.8	6.55
Min	68.8	16.5	124	4.05	61.0	18.25	2.2	5.8	8.4	12.0	5.05	2.1	1.3	1.6	-

Figure 5. Mechanical Diagram for QSP56

Table 7- Cable Length

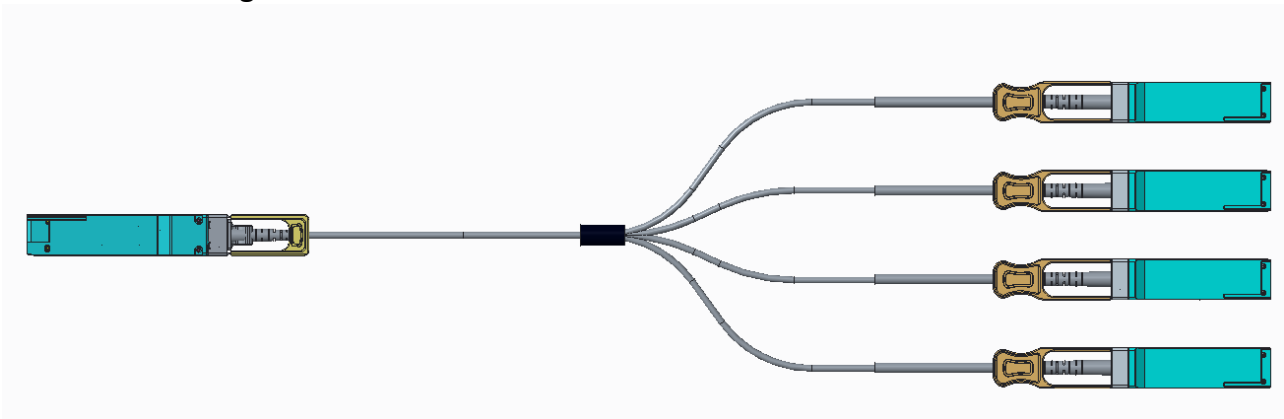

Figure 6, Mechanical Diagram of Cable

Table 8- Breakout Cable Nominal Length

Total Length X (Unit: m)	Breakout Point Measured from QSFP LQ (Unit: m)	Breakout Point Measured from SFP LS(Unit: m)
1	0.3	0.7
2	0.6	1.4
3	1	2
5	2	3
7	4	3
10	7	3
15	12	3
20	17	3
25	22	3
30	27	3
40	37	3
50	47	3

Warnings

Handling Precautions: This device is susceptible to damage as a result of electrostatic discharge (ESD).

A static free environment is highly recommended. Follow guidelines according to proper ESD procedures.

Laser Safety: Radiation emitted by laser devices can be dangerous to human eyes. Avoid eye exposure to direct or indirect radiation.

Contact:

E-mail: sales@robofiber.com

Web: www.robofiber.com

Address: 3000F Danville Blvd., Alamo, CA 94507 USA