

SFP-1000-RJ45

10G-BASE-T Copper SFP+ Transceiver

Features

- ◆ Supports Links up to 30m using Cat 6A Cable
- ◆ SFF-8431 and SFF-8432 MSA Compliant
- ◆ IEEE 802.3az and 802.3an Compliant
- ◆ IEEE 802.3bz for 5G&2.5G BASE-T
- ◆ Hot-pluggable SFP+ footprint
- ◆ TX Disable and RX Los function
- ◆ Fully metallic enclosure for Low EMI Emissions
- ◆ +3.3V single power supply
- ◆ Low Power Consumption (2.5W MAX @ 30m)
- ◆ Compact RJ-45 connector assembly
- ◆ Access to physical layer IC via 2-wire serial bus
- ◆ XFI/5GBASE-R/2500BASE-X/SGMII, SGMII Auto-Negotiation On
- ◆ Auto-negotiates with other 10GBase-T PHYs
- ◆ Supports 100/1000Base-T using Cat 5e cable or better
- ◆ MDI/MDIX Crossover
- ◆ Multiple Loopback Modes for Testing and Troubleshooting
- ◆ Built-in Cable Monitoring and Link Diagnostic
- ◆ Unshielded and Shielded cable support
- ◆ Operating case temperature range of 0°C to +70°C



Applications

- ◆ 10 Gigabit Ethernet over Cat 6A cable
- ◆ 5 Gigabit Ethernet over Cat 6A cable
- ◆ 2.5 Gigabit Ethernet over Cat 6A cable
- ◆ 1.25 Gigabit Ethernet over Cat 5e cable

Description

The SFP-1000-RJ45 Copper Small Form Pluggable Plus (SFP+) transceiver is a high performance, cost effective module compliant with the 10 Gigabit Ethernet and 10G BASE-T standards as specified in IEEE 802.3-2015 and IEEE 802.3an, which supports 10Gbps data-rate up to 30 meters reach over shielded twisted-pair category 6A cable. The module supports 10Gbps full duplex data-links with 16-level Pulse Amplitude Modulation (PAM) signals. The module provides standard serial ID information compliant with SFP+ MSA, which can be accessed with address of A0h via the 2wire serial bus. The physical IC can also be accessed via 2wire serial bus at address ACh.

Pin Definitions

Pin Diagram

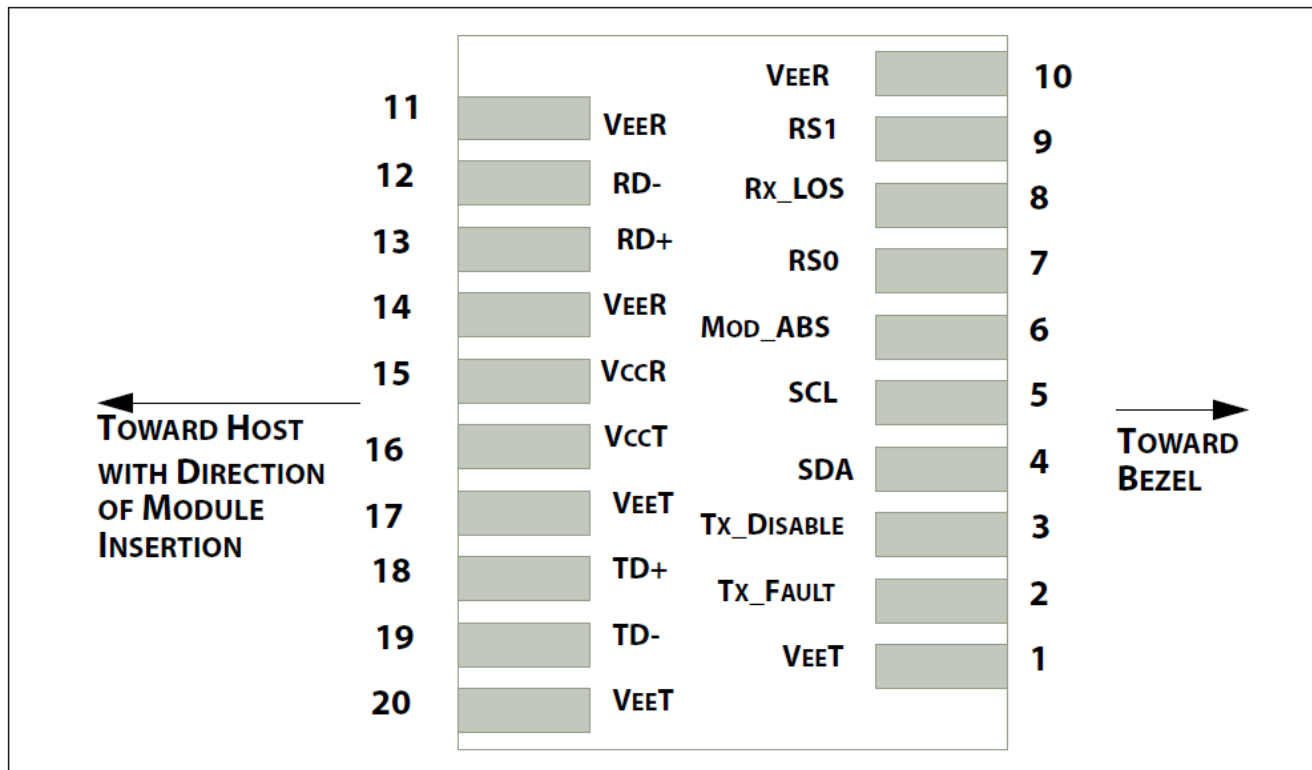

Figure 1. Pin Definitions

Pin Descriptions

Pin	Signal Name	Description	Notes
1	VeeT	Module Transmitter Ground	Note1
2	Tx_Fault	Module Transmitter Fault	Note2
3	Tx_Disable	Transmitter Disable; Turns off transmitter laser output	Note3
4	SDA	2-wire Serial Interface Data Line (Same as MOD-DEF2 in INF-8074i)	
5	SCL	2-wire Serial Interface Clock (Same as MOD-DEF1 in INF-8074i)	
6	Mod_ABS	Module Absent, connected to VeeT or VeeR in the module	
7	RS0	Rate Select 0, optionally controls SFP+ module receiver.	
8	Rx_LOS	Receiver Loss of Signal Indication (In FC designated as Rx_LOS and in Ethernet designated as Signal Detect)	Note2
9	RS1	Rate Select 1, optionally controls SFP+ module transmitter	
10	VeeR	Module Receiver Ground	Note1
11	VeeR	Module Receiver Ground	Note1
12	RD-	Receiver Inverted Data Output	
13	RD+	Receiver Non-Inverted Data Output	
14	VeeR	Module Receiver Ground	Note1
15	VccR	Module Receiver 3.3 V Supply	
16	VccT	Module Transmitter 3.3 V Supply	
17	VeeT	Module Transmitter Ground	Note1
18	TD+	Transmitter Non-Inverted Data Input	
19	TD-	Transmitter Inverted Data Input	
20	VeeT	Module Transmitter Ground	Note1

Note:

1. The module signal ground contacts, VeeR and VeeT, should be isolated from the module case.
2. This contact is an open collector/drain output contact and shall be pulled up on the host. Pull ups can be connected to one of several power supplies, however the host board.
3. Tx_Disable is an input contact with a 4.7 kΩ to 10 kΩ pullup to VccT inside the module.

+3.3V Volt Electrical Power Interface

+3.3V volt Electrical Power Interface						
Parameter	Symbol	Min	Typ	Max	Units	Notes/Conditions
Supply Current	Is		500	757	mA	2.5W max power over full range of voltage and temperature. See caution note below
Input Voltage	Vcc	3.13	3.3	3.47	V	Referenced to GND
Maximum Voltage	Vmax			3.6	V	

Low-speed signals, electronic characteristics

Low-Speed Signals, Electronic Characteristics						
Parameter	Symbol	Min	Max	Units	Notes/Conditions	
SFP+ Output LOW	VOL	0	0.5	V	4.7k to 10k pull-up to host_Vcc, measured at host side of connector	
SFP+ Output HIGH	VOH	host_Vcc - 0.5	host_Vcc + 0.3	V	4.7k to 10k pull-up to host_Vcc, measured at host side of connector	
SFP+ Input LOW	VIL	0	0.8	V	4.7k to 10k pull-up to Vcc, measured at SFP side of connector	
SFP+ Input HIGH	VIH	2	Vcc + 0.3	V	4.7k to 10k pull-up to Vcc, measured at SFP side of connector	

High-speed electrical interface, transmission line-SFP+

High-Speed Electrical Interface Transmission Line-SFP+						
Parameter	Symbol	Min	Typ	Max	Units	Notes/Conditions
Line Frequency	fL		800		MHz	16-level encoding, per IEEE 802.3
Tx Output Impedance	Zout,TX		100		Ohm	Differential, for all Frequencies between 1MHz and 800MHz
Rx Input Impedance	Zin,RX		100		Ohm	Differential, for all Frequencies between 1MHz and 800MHz

High-speed electrical interface, host-SFP+

High-Speed Electrical Interface, Host-SFP						
Parameter	Symbol	Min	Typ	Max	Units	Notes/Conditions
Single ended data input swing	Vinsing	500	800	1100	mV	Differential
Single ended data output swing	Voutsing	500	800	1100	mV	Differential
Rise/Fall Time	Tr,Tf	25		47	psec	20%-80%
Tx Input Impedance	Zin		100		Ohm	Differential

Rx Output Impedance	Zout	100	Ohm	Differential
---------------------	------	-----	-----	--------------

General specifications

General						
Parameter	Symbol	Min	Typ	Max	Units	Notes/Conditions
Data Rate	BR	1		10	Gbps	IEEE 802.3 compatible. See Notes 2 through 4 below
Cable Length	L			30	m	Category 6A STP. BER <10-12

Notes:

1. Clock tolerance is +/- 50 ppm
2. By default, the SFP-1000-RJ45 is a full duplex device in preferred master mode
3. Automatic crossover detection is enabled. External crossover cable is not required

Environmental specifications

Parameter	Symbol	Min	Typical	Max	Unit
Operating Case Temperature	Tc	0		+70	°C
Storage Temperature		-40		+85	°C

EEPROM Information

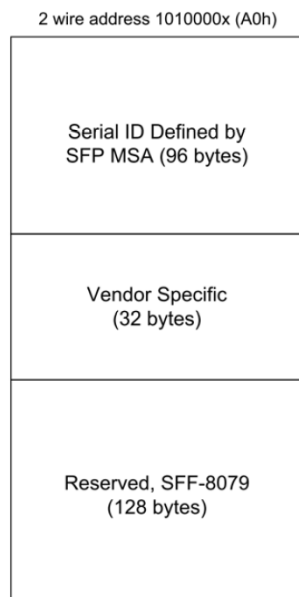

Figure 2. 2-wire Serial Memory Map

Physical Layer IC Register

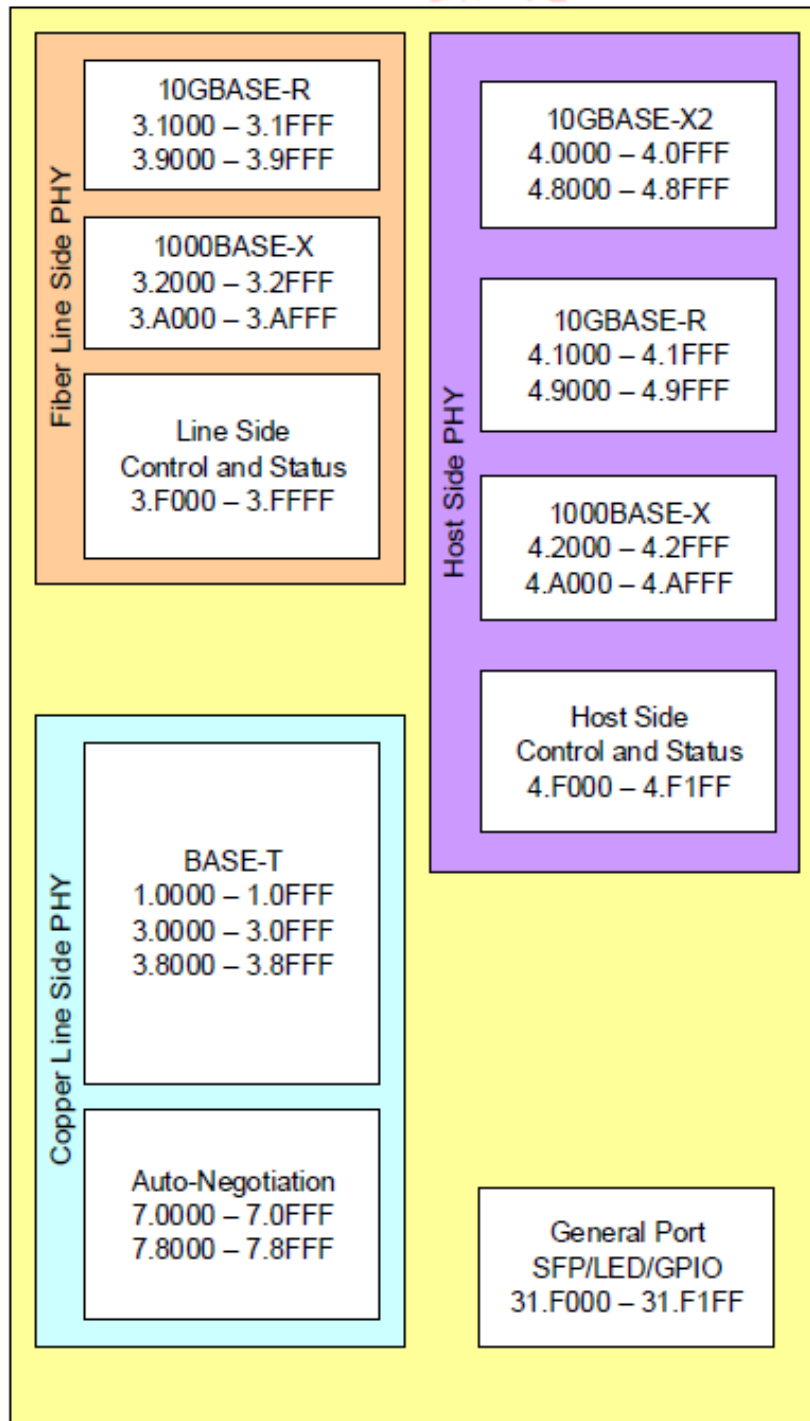

Figure 3. Phy IC Register List

Recommended Host Board Power Supply Circuit

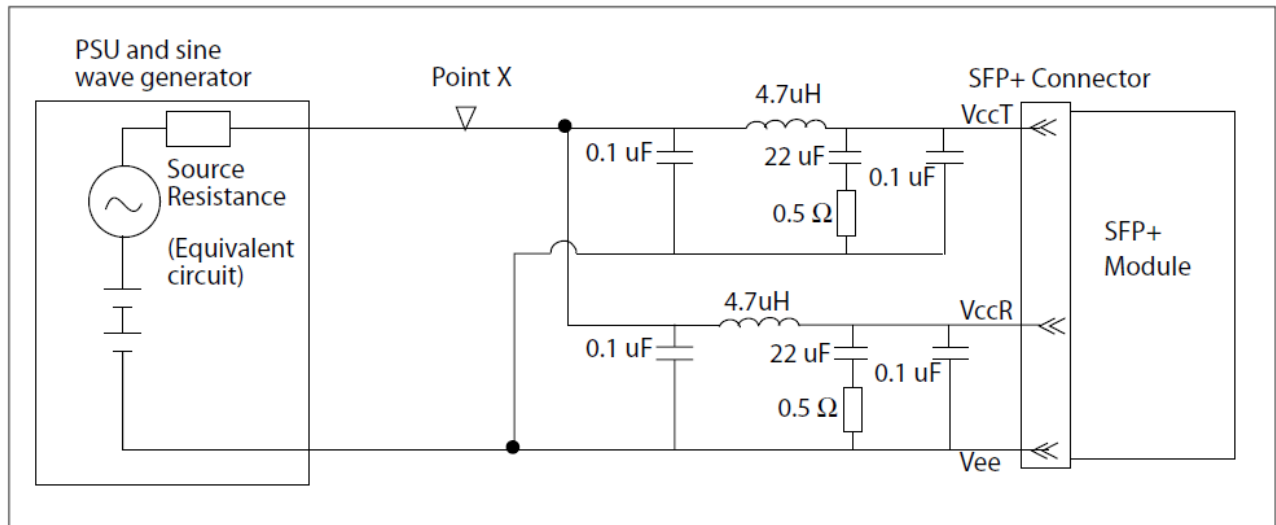

Figure 4. Recommended Host Board Power Supply Circuit

Recommended Interface Circuit

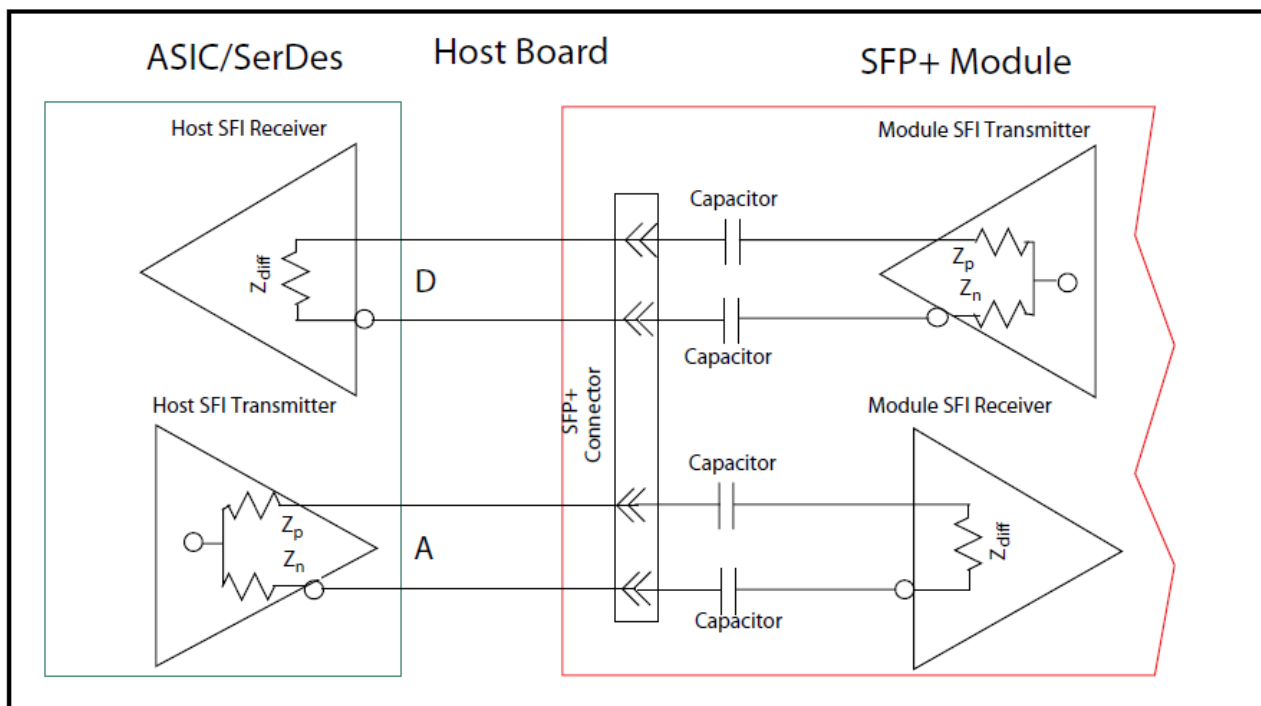
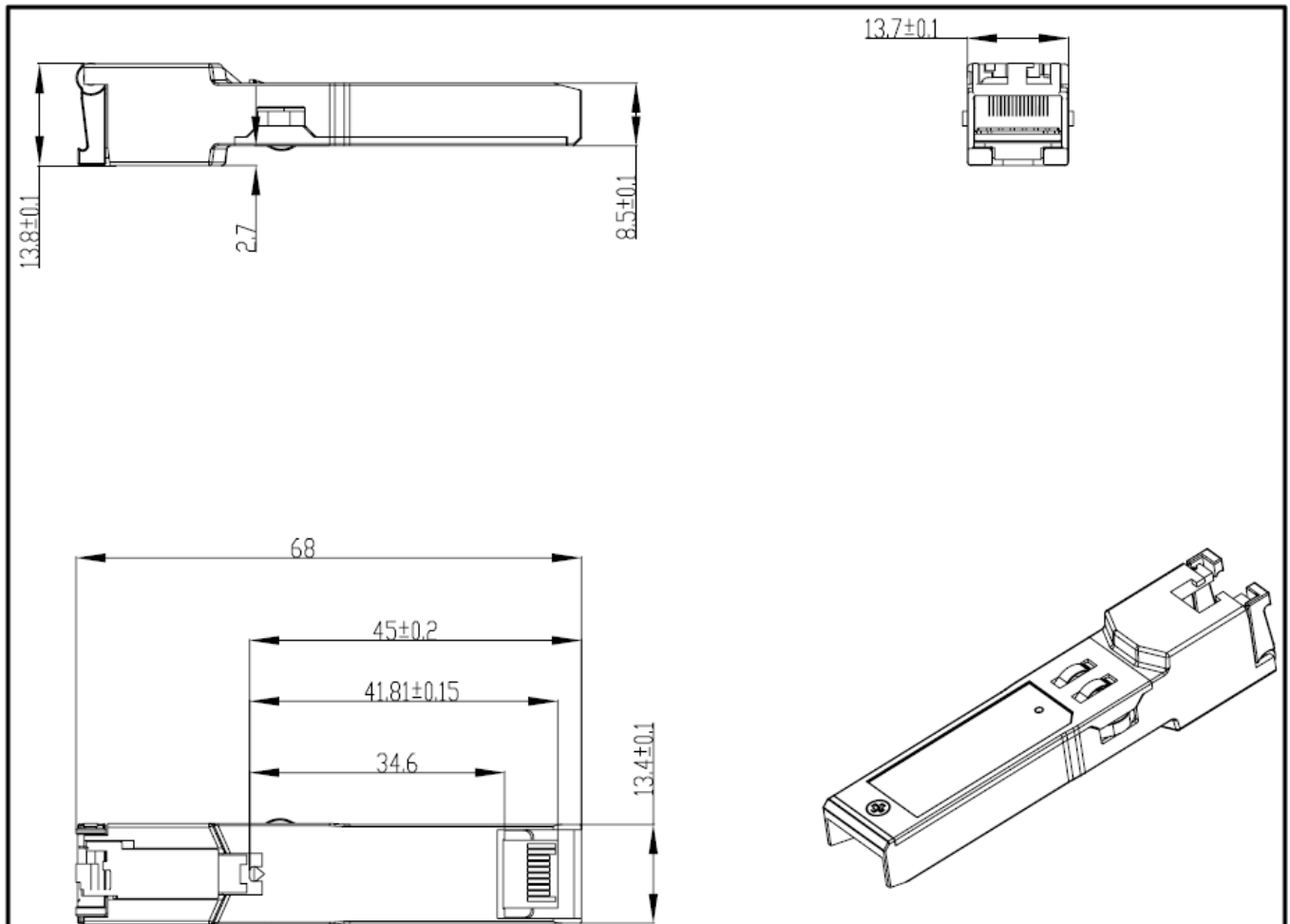

Figure 5. Recommended Host Board Power Supply Circuit

Mechanical Specifications

The host-side of the SFP-1000-RJ45 conforms to the mechanical specifications outlined in the SFP MSA1. The front portion of the SFP (part extending beyond the face plate of the host) is larger to accommodate the RJ-45 connector



Regulatory Compliance

Feature	Standard
Environmental protection	2011/65/EU
CE EMC	EN55032: 2015 EN55024: 2010+A1: 2015 EN61000-3-2:2014 EN61000-3-3:2013
FCC	FCC Part 15, Subpart B; ANSI C63.4-2014

Ordering Information

Part number	Speed mode	MAC interface	TX Disable function	Link Indicator on RX_LOS Pin	Temp
SFP-1000-RJ45	10Gbps	XFI/5GBASE-R/2500BASE-X/SGMII	YES	YES	0~70°C

References

1. Small Form Factor Pluggable Plus (SFP+) Transceiver Multi-Source Agreement (MSA), November 21, 2014.
2. IEEE802.3-2015.

Important Notice

Performance figures, data and any illustrative material provided in this data sheet are typical and must be specifically confirmed in writing by ROBOfiber before they become applicable to any particular order or contract. In accordance with the ROBOfiber policy of continuous improvement specifications may change without notice.

The publication of information in this data sheet does not imply freedom from patent or other protective rights of ROBOfiber or others. Further details are available from any ROBOfiber sales representative.

sales@robofiber.com